

M.S.R.A

MONTANA STREET ROD ASSOCIATION • 40TH YEAR

NEWSLETTER

WWW.MONTANASRA.ORG

SEPTEMBER, 2014

OFFICERS

BOB DEGENHARDT

President
PO Box 852
Bozeman, MT
Ph. (406) 219-3202
rdegenhardt@ecolibrum.com

ROGER BOOM

Vice President
507 S. 13th Ave.
Bozeman, MT
Ph. (406) 599-2380
rdboom@bresnan.net

MARILYN PATRICK

Secretary
Tony & Marilyn Patrick
11 Wathema
Butte, MT 59701
Ph. (406) 494-5243
sharpfocus@q.com

GREG STAPLES

Treasurer
4715 W. Larchwood Ct.
Spokane, WA 99208
Ph. (509) 466-9557
gstaples@aoipro.com

NEWSLETTER

Barb Salerno
1104 13th St. W.
Havre, MT 59501
Ph. (406) 265-3163
gitgo@bresnan.net

WEBSITE

Steve Sorg
307 E. Granite Ave.
Bozeman, MT 59718
Ph. (406) 582-7572
sorg1932@gmail.com

BOARD OF DIRECTORS:

Bob Degenhardt - President
Roger Boom - Vice President
Greg Staples - Treasure
Marilyn Patrick - Secretary
Dwight Wade - Past President
Steve Sorg - Past President
Larry Hart - Member at Large
Kelly Tribble - Business Sponsor Rep
Tony Patrick - Member Club Rep

NSRA MONTANA REPS:

- Eastern MT Rep
Tony Patrick - Western MT Rep

MONTANA SAFETY REP

Tommy Taylor

PREZ SEZ...

Fellow MSRA members and friends,

The summer rod run season has blown right past us (as is usual in Montana) except for one last hurrah - the Townsend Fall Fest and its car show on October 5th. The Fall Fest is well done and the car show is a good show. Surprisingly, the weather is regularly quite spectacular! Our upcoming meeting is in Townsend is on the same day as the car show. I hope you can join us there for both events.

On the agenda is the MSRA and participating car clubs scholarship activities. We need to get this program, which is our primary mission, shifted into high gear. Steve Sorg is our scholarship committee chairman and will undoubtedly lead a spirited discussion. We will also discuss next year's operating budget and take preliminary nominations for Street Rodder of the Year for 2014 (final voting in February 2015).

As always, please share your thoughts and ideas with us about MSRA.

See you in Townsend!

Bob Degenhardt

THE NEXT MEETING WILL BE HELD OCTOBER 5, 2014 AT:
Betsy's Restaurant, 219 Broadway St. , Townsend, MT
Sunday, October 5, 2014 • 10:00 a.m.

NEW MEMBERS & IDEAS WELCOME

The May 10, 2014 meeting of the Montana Street Rod Association was called to order by Bob Degenhardt, President, at 1:05 PM at Highlands College of Montana Tech, Butte, Montana.

There were 17 members in attendance. The meeting sign-in book was circulated for members and guests to sign. There were three guests present, George Smith, a member of the Pioneer Street Rods in Butte, Terry Bartle and Sonny Adams.

Bob Degenhardt thanked the Pioneer Street Rods for hosting the meeting and providing lunch. The meeting was held in conjunction with the NSRA Appreciation Day and Safety Inspections conducted by Tony Patrick, NSRA Western Montana Representative, and Tom Taylor, NSRA Montana Safety Inspector.

Minutes of the February, 2014 meeting were printed in the newsletter. Tony Patrick made a motion to dispense with the reading of the minutes. The motion was seconded by Roger Boom. The motion passed. Elizabeth Scholl made a motion to accept the minutes as printed in the newsletter. The motion was seconded by Bob Stredwick. The motion passed.

A report on the new MSRA printer was given by Marilyn Patrick.

Greg Staples, Treasurer, was not present at the meeting so there was no report given. However, the report will be included in the next newsletter.

Bob Degenhardt reported that a \$500.00 check was given to MSRA by the Hi-Line Cruz'n Association, Havre, MT. This check was given to the Scholarship fund.

Roger Boom gave a report on the MSRA Picks for 2014. All car club sponsors have requested an MSRA plaque for their events this year. The Pioneer Street Rods and the Helena Valley Timing Association have received their plaques. Roger will ensure that the other clubs will receive their plaque either by mail or by asking an MSRA member who will be attending a particular event to take the plaque with them. MSRA members are being asked to make the pick at the various events and follow the guidelines for the picks.

COMMITTEE REPORTS

A scholarship committee has been formed and members are Steve Sorg, Chair; Marilyn Patrick, Pioneer Street Rods; Elizabeth Scholl; Roger Mudd, Helena Timing Association; and Max Cederberg, Hi-Line Cruz'n Association. Other MSRA members are welcome to join the committee. They will hold a meeting following the regular MSRA meeting.

OLD BUSINESS

MSRA is hosting a 40th anniversary cruise to Loveland, Colorado in June. Members participating at this time include Steve and Judy Sorg (cruise captain), Tom Reeves, Bob and Fran Bradley, Jim and Kelly Rowlett, and Bob Basso/Phil Goeschl. Hotel arrangements are being made. Other MSRA members are encouraged to join this group on their adventure.

The Helena Valley Timing Association will be again hosting their Blast from the Past event in Helena on June 26-28, 2014. Roger Mudd gave a report on this event and encouraged members to make their hotel reservations if staying overnight.

The Pioneer Street Rods will host their annual charity cruise on July 12, 2014 in conjunction with the Montana Folk Festival. The event will take place in the heart of the Folk Festival in uptown Butte. Members were encouraged to make their room reservations if attending and staying overnight.

NEW BUSINESS

It was reported that 5 business sponsors, 7-8 individual/couples, and 1 club sponsor had not renewed their membership for 2014. A list was passed around that listed the names of those who had not renewed. If anyone knows these folks personally, it was suggested that they be contacted about renewing.

A color printer has been purchased for use by the Secretary to print out the hard copies of the newsletters and other association correspondence. This way we can continue to produce the newsletter in color. The printer should prove to be more cost

effective. This printer is expected to last about four years.

The next meeting date and location were discussed. A list of fall shows was discussed and two venues were decided as a location for the next meeting. Lewistown on August 9 and Townsend on October 5 were the favorite locations out of Libby, Billings, Lewistown, Townsend and Great Falls.

There will be a Father's Day gathering at the Stredwick property in Bozeman on Sunday, June 15, 2014. Roger Mudd said that 8 street cars are scheduled for the drag races on Sunday at Blast from the Past. The Colonial has blocked rooms and they are \$99.00 per night.

A motion to adjourn the meeting was made by Bob Stredwick. The motion was seconded by Gary Taylor. The motion passed.

Marilyn Patrick
Secretary



INTERESTING INFORMATION & COOL STUFF

- ◆ Potato salad will have more flavor if you whisk together all the dressing ingredients and add it to the potatoes when they are warm. The potatoes will absorb the ingredients better, and the flavor will develop even more during refrigeration.
- ◆ This one is one I am really going to remember since it hits pretty close to home.....if you are cooking or frying food and you walk away for what you (I) think is only a few minutes and all of a sudden you smell smoke (yes, this has happened to me!), douse a kitchen towel with white vinegar, wring it out and wave it around the room. It clears out the smoke smell right away, and the vinegar smell goes away just as quick. I am going to buy me a gallon of this vinegar, by golly!
- ◆ Rubbing alcohol can be used to remove ballpoint pen ink from most upholstery.
- ◆ Ice Pack: Partially fill a strong zip-lock type sandwich bag with Dawn dish washing liquid, close and freeze. Just to be safe, double bag it. Freeze. The liquid soap stays cold much longer and it can be re-frozen many times. It will conform to the place you need an ice pack.

Bus. (406) 265-7283 Toll Free: 1-855-265-7283
Fax (406) 265-3333

BALDWIN INSURANCE ASSOCIATES

Barb Salerno

Commercial Lines Account Manager
1465 U.S. Highway 2 NW, Suite D
Havre, MT 59501
Email: barb@baldwinlive.com

www.baldwininsuranceassociates.com

Call me to:

- + *Insure your Classic Car*
- + *Purchase a Title Bond*

Grundy Insurance
Hagerty Insurance
Condon & Skelley



"THE TRUSTED NAME IN TRANSMISSION & AUTO REPAIR"

406.265.7703
140 W 2nd Street
Havre, MT 59501

STEVE NEIFFER
Owner

RK Classics

*Custom Street Rod Fabricating
Parts and Equipment*



Ron Brandt
Owner - Manager

514 Mountain-View Drive • Bozeman, MT 59718
(406) 587-3064 • (406) 581-3879 Cell

"Hot Rods and Hot Paint"

McGinley Motorsports, LLP



Brett McGinley

4535 East Valley Center Rd • Bozeman, MT 59718
Phone: (406) 587-8616 • Fax: (406) 587-3836

Lube Alley

Jim Robinsen

651 West Oak
Bozeman, MT

406-586-4141



Silent Knight

MUFFLER & RADIATOR

JUSTIN HAAS

Exhaust System Specialists

630 E. Cottonwood
Bozeman, MT 59715

(406) 587-8500
silentknightmuffler.com

**Nickels Gaming
Parlor**

Bob Gilbert
2100 N. Last Chance Gulch
Helena, MT

406-443-5554

MSRA TREASURER'S REPORT

AS OF 4/30/2014

Treasurer's report

General fund: 4917.00
Scholarship Fund: 3177.85

Income YTD: \$1,025.00
MEMBERSHIPS \$425.00
BUSINESS SPONSORS \$400.00
CAR CLUB MEMBERSHIPS \$125.00
LICENSE PLATES \$ -
PATCHES \$ -
SCHOLARSHIP MERCHANDISE \$75.00

Expense YTD \$1,085.91
PRINTING \$132.60
POSTAGE \$59.24
PLAQUES \$ -
EVENT WALLET CARDS \$ -
LICENSE PLATES \$ -
PATCHES \$ -
MISCELLANEOUS \$379.07
WEB SITE \$ -
ACCOUNTING \$ -
STATE REGISTRATION \$ -
TRANSFER TO SCHOLARSHIP FUND \$515.00

Expense Transaction Detail:

CK#	Date	Pay To:	Expense	Amount
3048	1/28/14	Scholarship	fund transfer	465.00
3049	1/28/14	E. Scholl	printing/postage	187.72
3050	2/18/14	Scholarship	fund transfer	50.00
3051	2/18/14	S. Sorg	postage	4.12
3052	4/9/14	R Degenhardt	inkjet printer	379.07

HOGAN CORPORATION SERVICES

520 Business Hub
Belgrade, M 59714
Ph. (406) 388-9400

Tractors, RV's, Monthly-Yearly Leases, Fenced &
Secure, Commercial Space, Boat

Finishes

- CHROME
- NICKEL
- BRASS
- COPPER
- 24K GOLD

We Plate

- ALUMINUM
- STEEL
- POT METAL
- STAINLESS STEEL



Over 65 Years
Combined Experience!

Paul & Beckie
Graham
Owners

John Sanderson
Manager

2531 Dodge Avenue
Helena, MT 59601
(406) 449-6626
www.dipitnow.com

TEXTING CODES FOR SENIORS

TEXTING CODES FOR SENIORS

- ATD – At The Doctor
- BFF – Best Friend Fell
- BTW – Bring The Wheelchair
- BYOT – Bring Your Own Teeth
- FWIW – Forgot Where I Was
- GHA – Got Heartburn Again
- IMHO – Is My Hearing-Aid On
- LMDO – Laughing My Dentures Out
- TTYL – Talk to you Louder

**SUPPORT THE
BUSINESS
SPONSORS THAT
SUPPORT MONTANA
STREET ROD
ASSOCIATION**

Mike's Trim & Upholstery

Specializing in

- Automotive • Motorcycle • ATV • Marine
- Vinyl & Convertible Tops

Cell: 406.570.7853

Michael Wood

174 Shepherd Trail #A
P.O. Box 11947
Bozeman, MT 59719

Simply Designed

Ken Hackler
406.570.1846
305 Sanders Ave., Bozeman, MT

ECOLIBRIUM
A BETTER ENVIRONMENT FOR BUSINESS.

Elizabeth Schuyler Scholl
CHAIRMAN AND CHIEF EXECUTIVE OFFICER

Ecolibrium.com
escholl@ecolibrium.com
PO Box 852, Bozeman, MT 59711-0852
Mobile 406.579.2996 Tel 406.219.3202

Printed on recycled paper

First Interstate Bank

Anna Craver
Customer Service Supervisor

First Interstate Bank
2023 Burke Street
P.O. Box 10910
Bozeman, MT 59719-0910
Tel: (406) 556-4846
Fax: (406) 556-1068
e-mail: anna.craver@fib.com

www.firstinterstatebank.com

S A M
SHINES AUTOS METICULOUSLY

**PROFESSIONAL
DETAILING SERVICES**

SAM HAUGSTUEN
owner

214 Shepherd Trail Unit E
Bozeman, MT 59718

406-209-3058
www.shinesautosmeticulously.com
sam@shinesautosmeticulously.com

LinkedIn

Torquing Wheel Lug Nuts / Lug Bolts

Over the years, we've seen firsthand the ramifications of improperly torqued lug nut and lug bolts. We've seen wheels come off, brakes damaged, broken and/or stripped lug nuts, bolts and studs. And unfortunately, we have seen this time-and-again from professional technicians as well as the do-it-yourselfers - all for one simple reason - they failed to properly torque the lug nuts or bolts on their vehicles.

Lug studs and nuts as well as lug bolts are designed with a specific grade of hardware with a certain amount of "stretch." Stretch? You might ask - Yes. Proper torque, which stretches the bolt, causes the threads of the stud/bolt to tightly mate and secure to the matching nut or threaded hole (within the axle or wheel hub) without working themselves loose. It's akin to mechanically securing the nut to the bolt - except that you can remove and re-tighten it repeatedly, as needed., yet, most bolt grades used for this purpose will retain its original size and properties (un-stretched) when properly torqued to specifications. The properties of the bolt has a slight spring affect when loosened.

The below are examples of bolts in the various stages of torque:

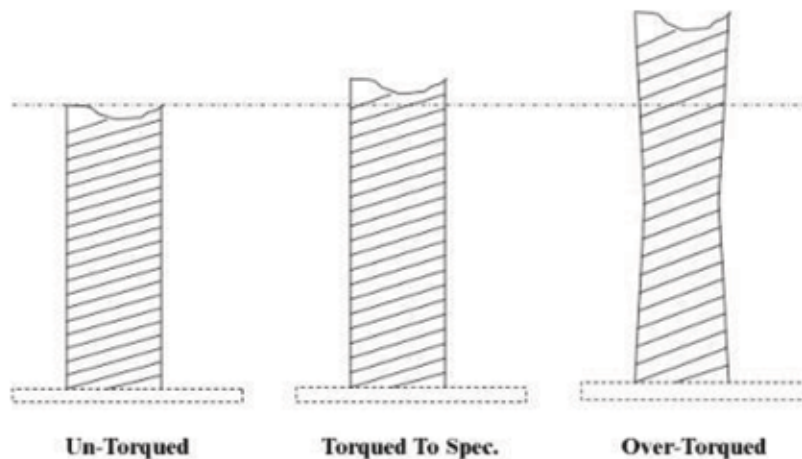

1. The first example is a bolt that is loose, with no torque applied — unstretched.
2. The second example is a bolt that is torqued to specification. There is a slight amount of stretch, but not enough to change metal/alloy properties of the bolt and it returns back to it's original shape and is ready for for retorquing.
3. The third example is a typical of an over-torqued bolt. Note that the bolt has not only stretched, but stretched to the point of changing the properties and yield strength of the bolt. The bolt now has a much lower tensile/yield strength and allows the bolt to flex, generate heat and fatigue. A bolt that has been over-torqued will be prone to cracking, shearing, loosening, or breaking off which can result in damage to the wheel and other related components.

Improperly torqued lug nuts or bolts can also result in:

- Warped brake rotors — brakes grabbing, pulsating or overheated.
- Damage to the lug nut seating surface of alloy wheels.
- Wheel hub damage — threaded wholes stripped out.

It is also important to tighten lug nuts or bolts incrementally to the final torque specification, and doing so in the proper sequence.

The graphic below shows the three common bolt patterns and tightening sequences, appropriate for most automotive applications.

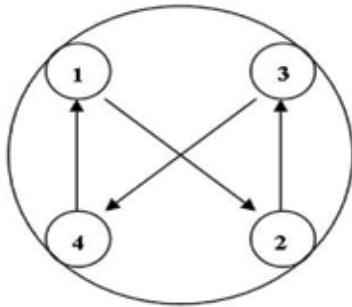

Four-Bolt

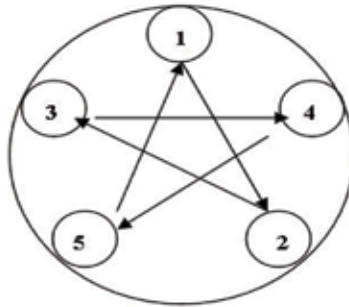

Five-Bolt

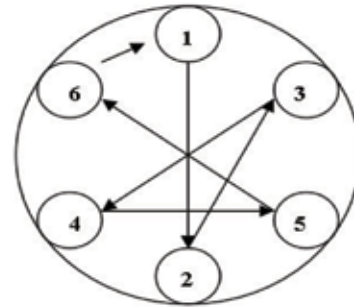

Six-Bolt

It is prudent to recheck the torque specifications after a test drive the vehicle, especially with alloy or painted wheels. It is very possible to falsely torque lug nuts or bolts due to excess paint, debris, corrosion or a tight and binding centering hole over the wheel hub that allows the bolt or nut to come loose after the vibrations and rigors of driving.

When installing new wheels you should re-torque the wheel lugs after driving the first 50 to 100 miles in case the clamping loads have changed following the initial installation. This is necessary due to the possibility of metal compression/elongation or thermal stresses affecting the wheels as they are breaking in, as well as to verify the accuracy of the original installation. When rechecking torque value, wait for the wheels to cool to ambient temperature (never torque a hot wheel). Loosen and retighten to value, in sequence. Simply repeat the same torque procedure listed above.

General Torque Specifications

Hardware Bolt or Stud Size	Typical Torque Range in Ft/Lbs	Minimum Number of Turns of Hardware Engagement
12 x 1.5 mm	70 - 80	6.5
12 x 1.25 mm	70 - 80	8
14 x 1.5 mm	85 - 90	7.5
14 x 1.25 mm	85 - 90	9
7/16 in.	70 - 80	8
1/2 in.	75 - 85	8
9/16 in.	135 - 145	8

Wheel lug torque specifications are for clean threads that are free of dirt, grit, etc. If applying an anti-seize lubricant, it is important to note it can be applied only on the threads of nuts or bolts. The lubricant must not be used on either seat of the hardware of the wheel. With the seat being the main point of friction where torque is measured, extreme caution must be used if an anti-seize lubricant is applied to the threads as excess can either drip or be pushed onto the lug seat resulting in inaccurate torque values.

A thread chaser or tap should be used to remove any burrs or obstructions of the threads allowing the lug hardware to be turned by hand until it meets the wheel's lug seat. Once lugs are snugged down, finish tightening them with an accurate torque wrench. Use the appropriate crisscross sequence (shown above) for the number of wheel lugs on your vehicle until all have reached their proper torque value. Be careful because if you over-torque a wheel, you can strip a lug nut or hub, stretch or break a stud or bolt, and cause the wheel, brake rotor and/or brake drum to distort.



John Zowada
Store Manager

NAPA AUTO PARTS BOZEMAN Store 406-587-9211
2616 W Main Suite A Cell 406-647-8874
Bozeman, MT 59718. poisoncreekinc@gmail.com



Michael Brush
Store Manager

34224 Frontage Rd.
Bozeman, MT 59715

office 406-587-4726
fax 406-522-9332
email Michael.Brush@NCS-Coatings.com
web www.NCS-Coatings.com

"Total Coating Solutions"



509-467-9860
www.aoipro.com

9515 N Division
Suite 105
Spokane, WA 99218

Professional Software Solutions

Gregory O. Staples, M.S.
President

gstaples@aoipro.com



Brandon Mead
bmeadstudio@gmail.com • Bozeman, MT



586-6809
Mobile: 580-7165
5601 Monforton Rd.
Bozeman, MT 59718



Jake Gustavsen
SALES

Montana's Best Gas and
Welding Distributor Since 1948

103 BRIDGER CENTER DR.
BOZEMAN, MT 59715
MAIN: 406.586.5927
FAX: 406.586.9674
1.800.332.9353
CELL: 406.491.5025

WEB SITE: www.gendco.com
E-MAIL: jake@gendco.com



- ▶ Log Home Restoration
- ▶ Deck/Patio Restoration
- ▶ Brick Restoration
- ▶ Chinking & Caulking
- ▶ Mold Remediation
- ▶ Staining & Resurfacing
- ▶ Auto Body / Metals
- ▶ Fire Damage
- ▶ Parking Lots / Driveways
- ▶ Bridges

406.581.1588

8264 Huffine Lane | Bozeman, MT 59718

BLASTINGTECHNOLOGIES.COM



**Bozeman
Transmission Center**
7680 Shedhorn Dr. • Bozeman, MT 59718

- SW MT's Oldest, Most Experienced Transmission & Drivetrain Rebuilding & Repair Facility
- Automatic & Standard Transmission for all makes & models
- Clutches, Transfer Cases and Differentials
- H.D. Automatic Transmissions for Diesels, 4x4 Towing Units, R.V.'s & Performance Vehicles
- Transmissions for Vintage & Muscle Cars

Phone 586-5097
Area's Only Transmission Dyno

Earl Jolliff
A.T.R.A. Certified Technicians

THINGS THAT MAKE YOU GO HUMMMMMMM.....

THINGS THAT MAKE YOU GO HUMMMMMMM.....

- Why does a round pizza come in a square box?
- What disease did cured ham actually have?
- How is it that we put man on the moon before we figured out it would be a good idea to put wheels on luggage?
- Why do people pay to go up tall buildings and then put money in binoculars to look at things on the ground?
- Why do doctors leave the room while you change? They're going to see you naked anyway...
- If corn oil is made from corn, and vegetable oil is made from vegetables, what is baby oil made from?
- Why does Goofy stand erect while Pluto remains on all fours? They're both dogs!
- Did you ever notice that when you blow in a dog's face, he gets mad at you, but when you take him for a car ride, he likes to stick his head out the window?
- Why are you IN a movie but ON TV?
- Why is "bra" singular and "panties" plural?

AL'S MOBILE GLASS
Full Line of Glass & Mirrors
AUTOS • TRUCKS • COMMERCIAL • RESIDENTIAL
FARM & RANCH • LICENSED & INSURED
— NEW VINYL REPLACEMENT WINDOWS —
99 East Highway 2 • Whitehall, MT 59759
Phone (406) 287-2194 • Cell 490-0085 • Fax 287-7955

**RAVON**
STREET RODS
Steve Poore *owner*
c 406.580.4128
o 406.388.7867
ravn@mcn.net
ravnstreetrods.com

Randash Auto, Inc.
Edward V. Randash
406.670.5577
5124 Laurel Rd., Billings, MT 59101
www.randashauto.com

**Reggie's Auto Body
and Rod Shop**
Reggie and Val Dangerfield
338 Naylor St., Billings, MT 59101

Axle Flange Housing Identification

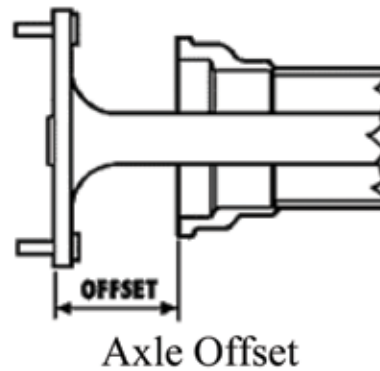
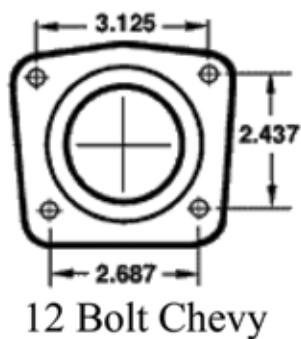
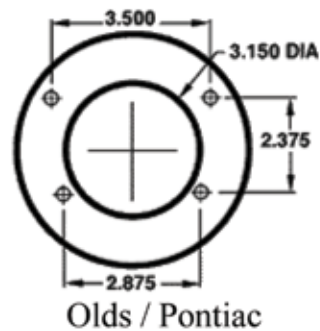
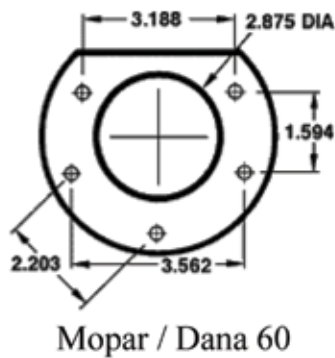
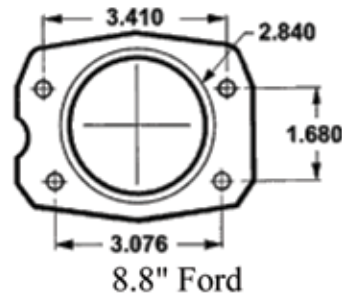
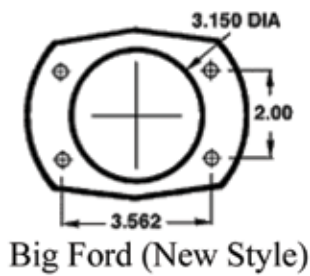
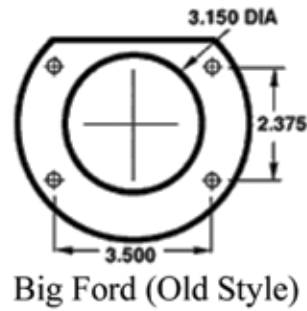
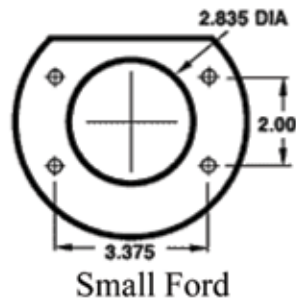

Please send all news articles, classified ads, special interest articles, stories of trips you took, etc. to:

**Barb Salerno
1104 W. 13th St.
Havre, MT 59501**

Ph. (406)265-3163

Email: gitgo@bresnan.net

**MONTANA STREET ROD
ITEMS
ARE NOW AVAILABLE:**

- PATCHES \$ 10.00
- CAN KOOZIES \$ 4.00
- PLAQUES \$ 25.00

To order, call Elizabeth Scholl
(406) 219-3202

Or

Email: escholl@ecolibrium.com

Paul Bunyan's Sandwich Shop

JIM AYERS
3150 BUSCH STREET
BUTTE, MT

406-494-7817

FOR SALE

**1951 Dodge Wayfarer, 2-door sedan, new Upholstery, all original, 95% complete.
Great project car.**

\$3500

Also available is a 318 motor.

**For more information, call John at
503-385-6920**

1938 Dodge Pickup

**Can be used for parts or as a project car
\$1500**

**Call Ron Brandt
406-597-3064**



1932 Ford pickup rolling chassis includes: pickup bed; four 15" chrome reverse wheels; original 'K' member and cross members; front fender braces; radiator; headlight bar; and steering box and column with original key in column lock. The torque tube and rear end were chromed in the 1960's
Price: \$3500

Wally Hammett, Roundup, MT

Phone: 406.323.1695

email: whammett30sotonsra@midrivers.com

1989 Ford Thunderbird
Super Coupe, Supercharged V6
5 speed Transmission, All options available
41K one-owner miles
Dark Blue/Gray Interior Retail Value: \$10,300
Steal it today for \$8995 FIRM
Call Fred at 406-490-7139

40TH MSRA ANNIVERSARY CRUISE

TUESDAY JUNE 3 THROUGH MONDAY JUNE 9

MONTANA STREET ROD ASSOCIATION 40TH ANNIVERSARY CRUISE TO LOVELAND

Tuesday, June 3rd through Monday, June 9th

Five cars made the trip to the Goodguy's show at Loveland, CO in June. We drove mostly two lane highways on the trip through Yellowstone and Teton National Parks. The scenery was spectacular. At the end of the Goodguy's show, we went our different ways and all made it back home via different routes and on different days.

We stopped at WyoTech in Laramie, WY on the way to Loveland and toured the Auto Upholstery and Street Rod Fabrication shops and spoke with students and instructors in each program. When we came back out to our cars to resume our trip, we were greeted by quite a few students and instructors who were on break and checking out our cars. It was nice to talk with them!

On the return trip, two cars returned to Bozeman through Cody, WY, across the Chief Joseph Highway and over the Beartooth Highway. Lots of snow and beautiful scenery!

Below are some photos from the trip.



40TH MSRA ANNIVERSARY CRUISE

CONTINUED



CUSTOM COLLISION REPAIR

PHONE: 406.265.8492 | CELL: 406.945.1923 | FAX: 406.265.3185
1710 1ST STREET NE | HAVRE, MT 59501 | CCRBODY@BMI.NET

CHRIS PREPUTIN

Owner

Professional Auto & Light Truck Repair



• Kelly Tribble •
Providing quality, professional service.
• Over 20 years experience.
• Serving Three Forks and surrounding areas.

Windy Ridge

ENTERPRISES

Office 285-4571 • Cell 539-0794
857 Boulder Cutoff Rd (Milligan Canyon exit) Cardwell, MT 59721

MSRA BUSINESS SPONSORSHIPS

If you are a business owner and would like to become a business sponsor of MSRA, send your business card or a copy of your ad to:

Elizabeth Scholl
PO Box 1423
Bozeman, MT 59771-1423

Cost: \$50 per year

Your fees go toward the MSRA Scholarship Fund

You will receive:

- MSRA Business Sponsorship Plaque
- Advertising in the Newsletter
- Advertising on the MSRA Website

MSRA MEMBERSHIPS FOR CAR CLUBS ARE AVAILABLE

\$25 PER YEAR

BENEFITS:

- ❖ You can have your rod run registration/advertisement printed in the newsletter that goes out to 120 memberships.
- ❖ You can advertise any club fundraisers.
- ❖ You can put articles in the newsletter.
- ❖ You can advertise "FOR SALE" vehicles, parts, etc. in the newsletter and on the website.
- ❖ Your name will appear on the website as a club member.

FOR SALE

1953 Ford Pickup, S-10 Front Suspension Clip, 302 automatic overdrive, nicely upholstered, great stereo system.

Asking \$10,000

Great Starter For The Price

Call Gordon Stroh(406) 388-2955

FOR SALE

1942 Pontiac 2 door Fastback \$1000
1947 Buick 2 door Fast Back
1950 Buick 2 door Fast Back w/Camaro Sub-Frame
1950 Buick 4 door
1957 Buick Convertible Special
1966 Plymouth Sport Fury Convertible \$5800
2 ea. 1947 Buick 2 door Fast Back Road-master
1948 Buick Super 4 door
1949 Buick 2 door Fast Back
2 ea. 1950 Buick 2 door Hard Top

Call Reggie Dangerfield
(406) 252-3301



**UNITING GEAR HEADS YOUNG AND OLD
HELP SUPPORT THE MONTANA STREET ROD
ASSOCIATION**

SCHOLARSHIP PROGRAM

PURCHASE MSRA MERCHANDISE!

Our goal is to create a sustainable way to annually fund at least a \$500 scholarship to each of the six Montana tech schools that offer automotive or related programs. All net proceeds from all sales will go directly to the scholarship fund.

The first items available for sale are can Koozies. Additional items, such as t-shirts, caps, etc. will be available soon – watch the MSRA web site for availability (www.MontanaSRA.org)

CAN KOOZIES -- \$4.00 each

Can Koozies will be available for purchase at all MSRA meetings. Also, they can be purchased from all MSRA officers. In addition, Koozies will be for sale at selected car shows during the upcoming summer season.

**THANK YOU FOR SUPPORTING EDUCATION
FOR MONTANA KIDS!!**